

LifeFitness

Arctic Silver 91T Treadmill

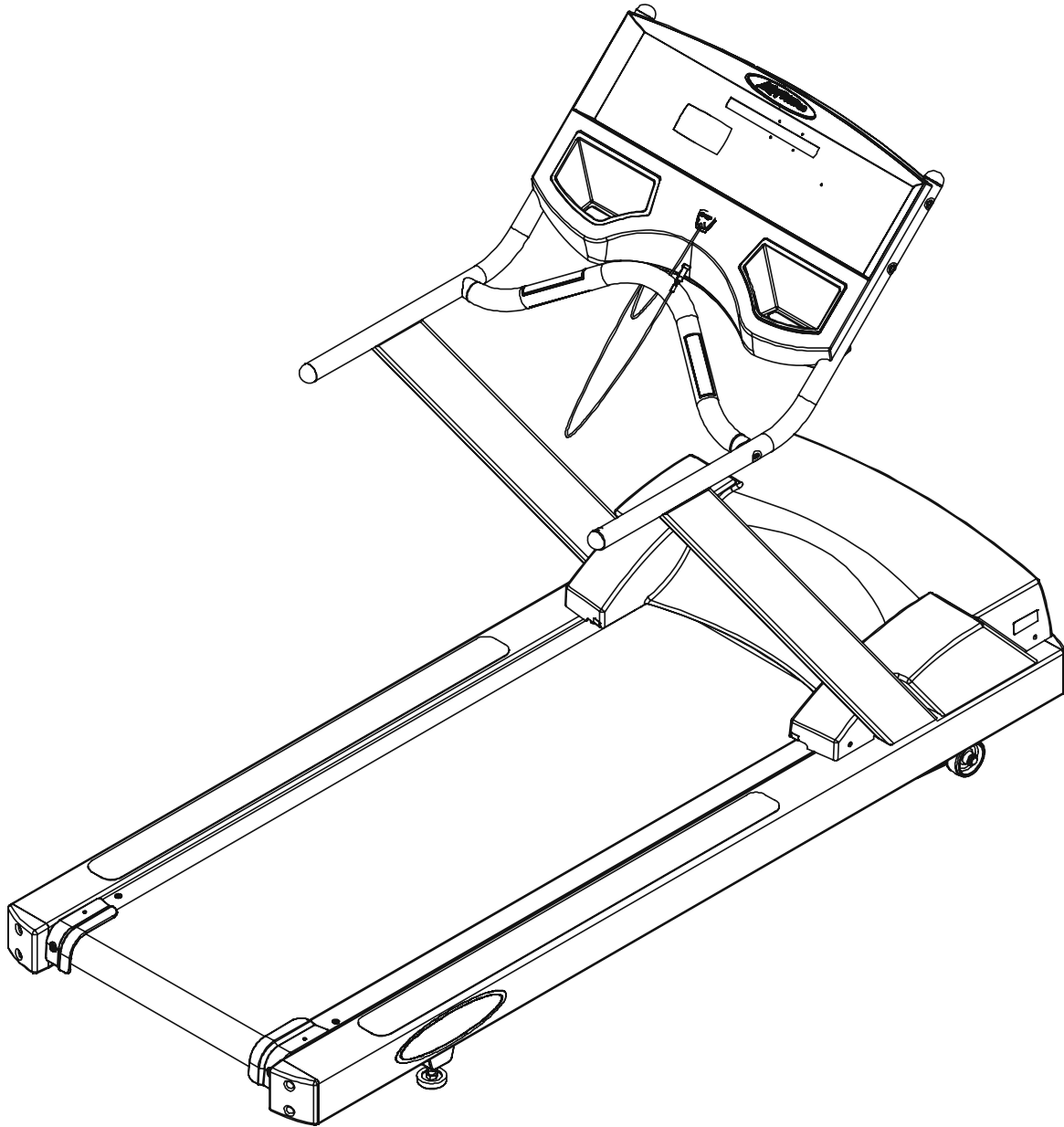

Customer Support Services
PARTS MANUAL rev. 12 Apr 2012

ARCTIC SILVER 91TW
REFERENCES

91T-0XXX-04
S/N ATZ100000 and up

PLEASE NOTE: ALL OPERATION, INSTRUCTION ASSY & INSTRUCTION BAG ASSY MAY NOT AVAILABLE				
LANGUAGE	OPERATION MANUAL	INSTRUCTION ASSEMBLY	INSTRUCTION BAG ASSY.	SERVICE MANUAL
ENGLISH	M051-00K60-A028	M051-00K60-B024	AK60-00138-0000	M051-00K60-A023
FRENCH	M051-00K60-A029	M051-00K60-B025	AK60-00138-0001	
PORTUGUESE				
SPANISH				
DUTCH	M051-00K60-B030	M051-00K60-B026	AK60-00138-0002	
GERMAN				
ITALIAN				
JAPANESE	M051-00K60-A031	M051-00K60-B027	AK60-00138-0003	

AK60-00162-0000	HDWR-BAG ASSY: MFG; 91TW BM	
Item	Description	Qty
0K60-01098-0001	END-CAP: SPHERE B	4
0K60-01157-0000	SPRING: ERGO-BAR B	1
0017-00021-2846	CONN FTYPE PNL F01S RD GP F B	1
0017-00042-1151	RIVET: PLASTIC; REMOVABLE B	5
0017-00101-1256	3/8 -16X80 UNS HEX BLT G5 ZN B	4
0017-00101-1767	1/4 -20X28 TRX BUT L CS G8 ZS B	4
0017-00101-1768	1/4 -20X32 TRX BUT L CS G8 ZS B	2
0017-00101-1776	10-16X 8 PHL PAN B ST ZB B	10
0017-00103-0188	NUT 3/8 -16 LOCK-FLNGE D ST CD B	4
0017-00104-0464	WSH 406-.734-064 FL-D ST ZS B	4

TOUCH UP PAINT:	
0017-00008-0204	PAINT: CAN; SPRAY; ARCTIC SILVER
0017-00008-0205	PAINT: BOTTLE; ARCTIC SILVER (.5 OZ)
0017-00008-0206	PAINT: PEN; ARCTIC SILVER (.33 OZ)

ENTERTAINMENT READY PRODUCT	
This product is preconfigured to accept the addition of the Life Fitness Entertainment System. A POWER CABLE and COAXIAL CABLE have been pre-installed.	
AK32-00078-0001	CBL-ASSY: PWR EXT; 120" S/C-C
AK32-00020-0002	CBL-ASSY: COAX; 120" S/C-B

	Page
CONSOLE ASSEMBLY	5
MOTOR COVER, LEVELER & END CAPS	8
ERGO BAR & UPRIGHT ASSEMBLY	9
ACCESSORY TRAYS	10
BELT, DECK & ROLLERS	11
LIFESPINGS & ANTI-STATIC TINSEL	12
LIFT FRAME ASSEMBLY	13
LIFT MOTOR AND HOME SWITCH	14
DRIVE MOTOR ASSEMBLY	15
WAX PUMP, BAG, NOZZLE AND BRACKET	16
SENSORS	17
REAR ROLLER GUARDS AND ADJUSTMENT BOLTS	18
DC CONTROLLER AND ON/OFF SWITCH	19
LINE FILTER	20
LINE-CORD AND LINE-CORD OPTIONS	21
CABLES	22

LANGUAGE	CONSOLE	OVERLAY/BEZEL ASSY
ENG/ENG	AK60-00111-0001	AK60-00108-0001
GERMAN	AK60-00111-0003	AK60-00108-0003
SPANISH	AK60-00111-0004	AK60-00108-0004
JAPANESE	AK60-00111-0006	AK60-00108-0006
FRENCH	AK60-00111-0007	AK60-00108-0007
ITALIAN	AK60-00111-0008	AK60-00108-0008
DUTCH	AK60-00111-0009	AK60-00108-0009
PORUGUESE	AK60-00111-0010	AK60-00108-0010

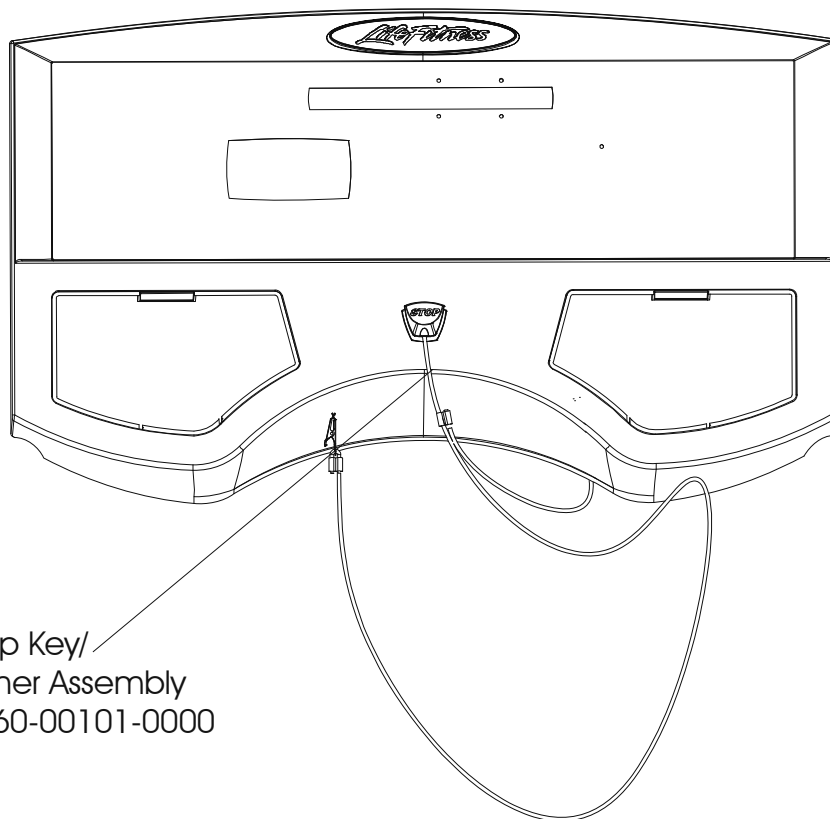

ARCTIC SILVER 91TW
Console Assembly (2 of 3)

91T-0XXX-04
S/N ATZ100000 and up

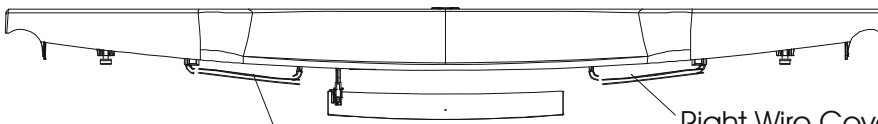
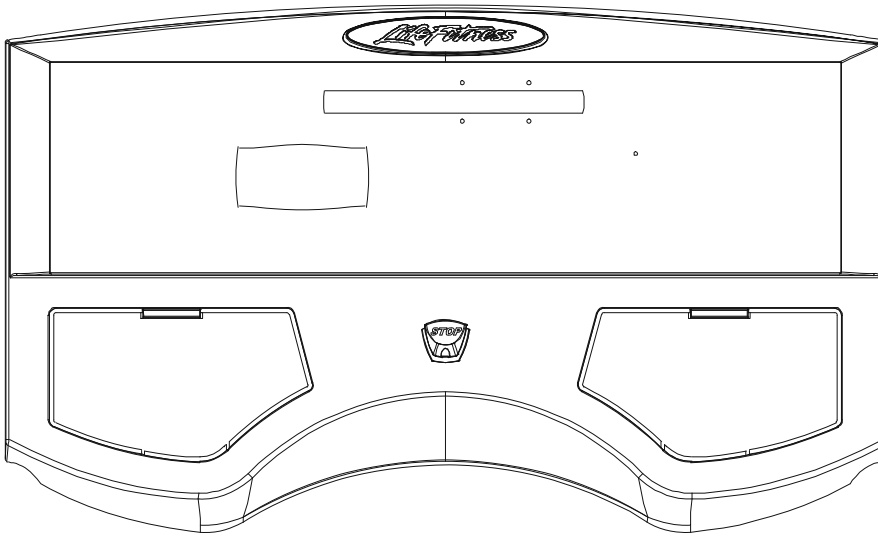

Left Wire Cover
OK60-01041-0003

Right Wire Cover
OK60-01041-0004

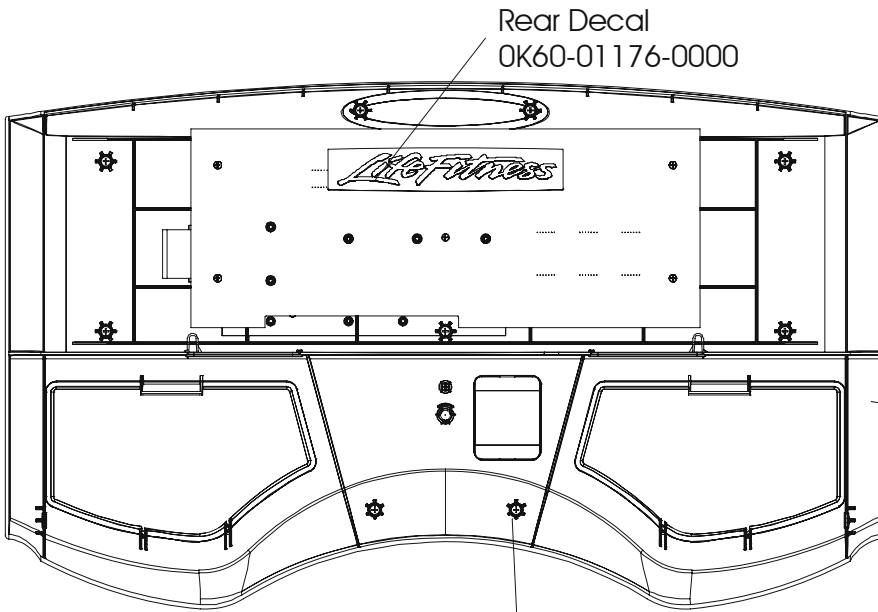

Rear Decal
OK60-01176-0000

Rear Console Case
OK60-01072-0001

Phillips Screw(9)
0017-00101-1288

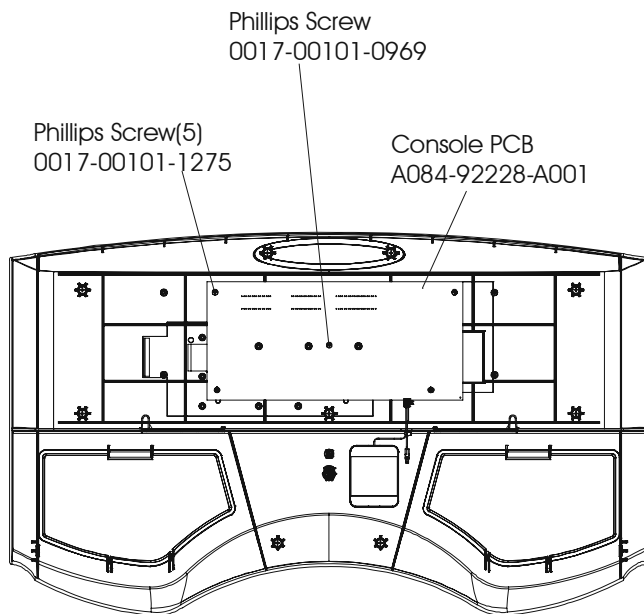
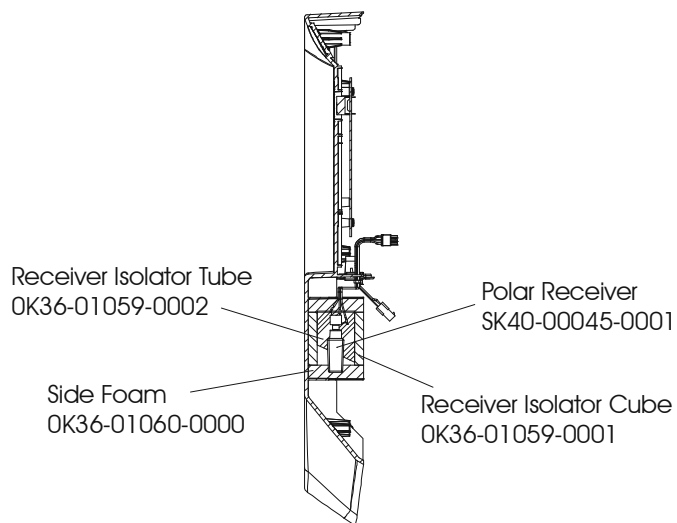
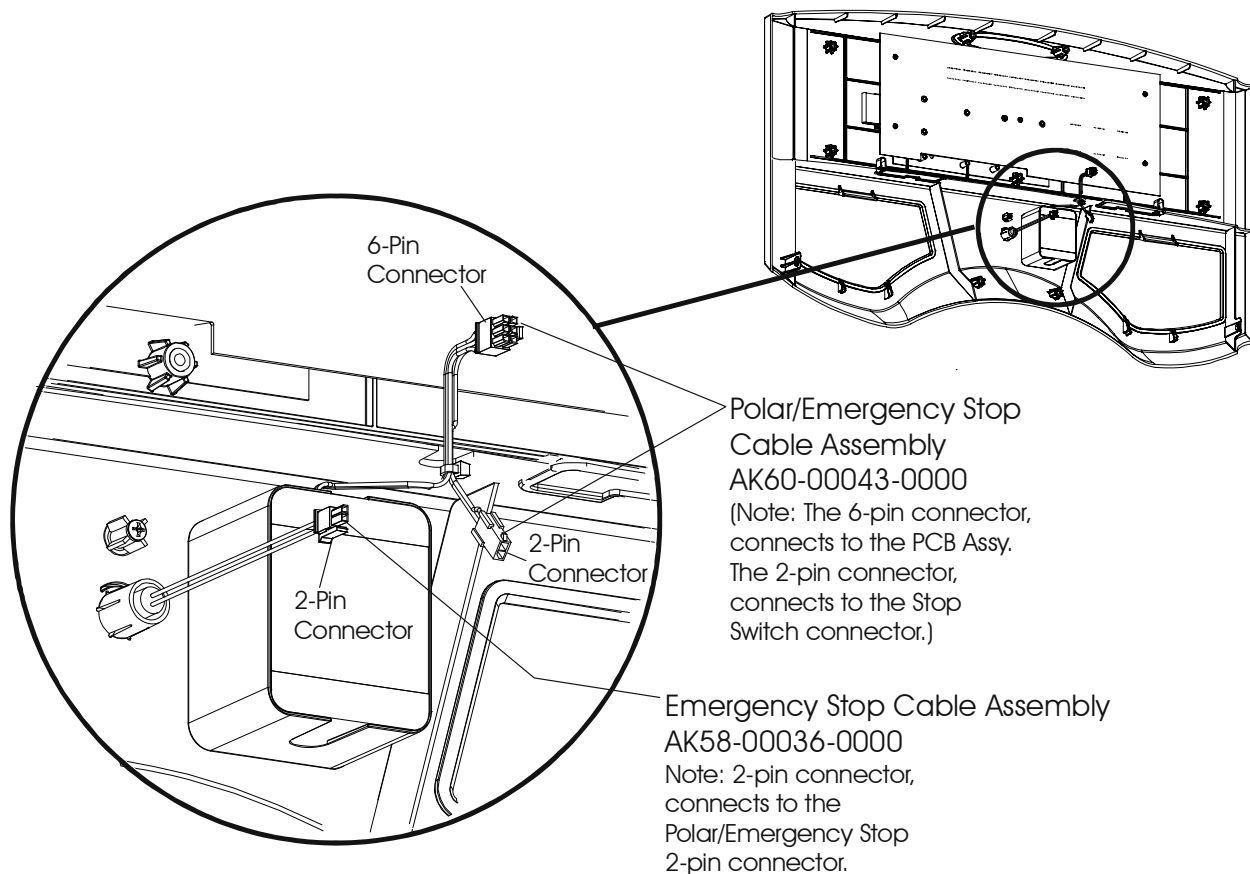

ARCTIC SILVER 91TW
Motor Cover, Leveler and End Caps

91T-0XXX-04
S/N ATZ100000 and up

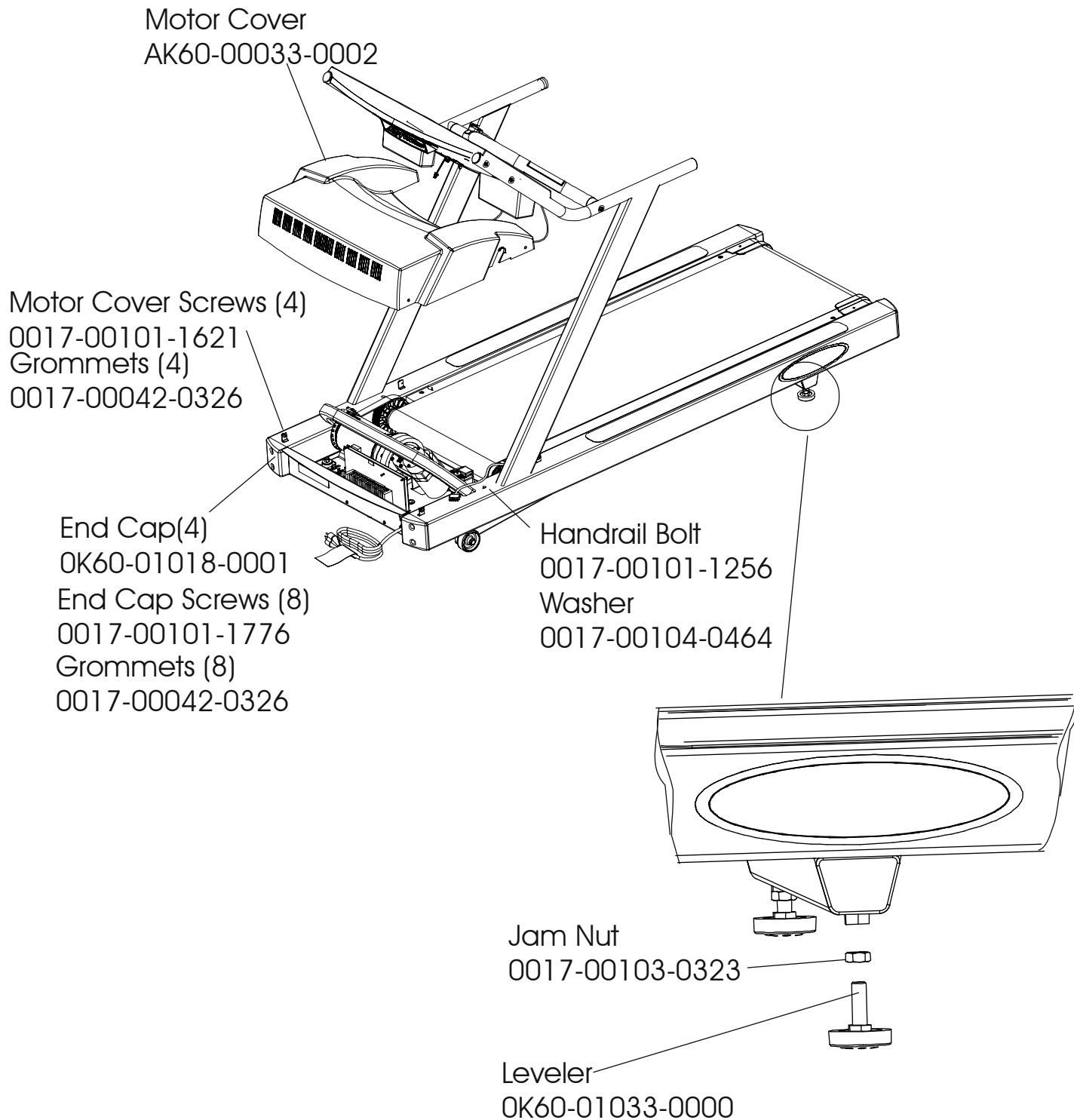

ARCTIC SILVER 91TW
Ergo Bar and Upright Assembly

91T-0XXX-04
S/N ATZ100000 and up

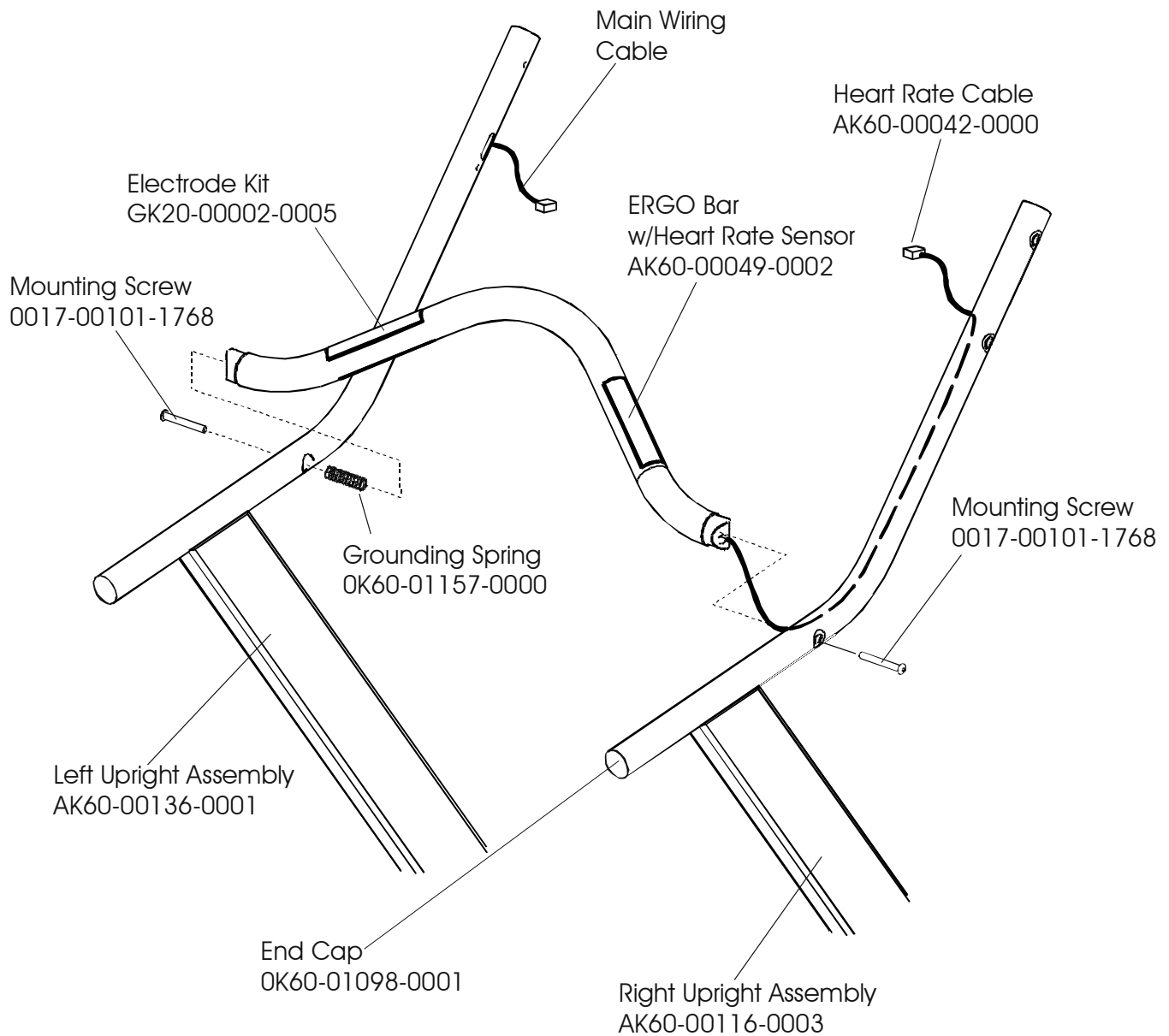

ARCTIC SILVER 91TW
Accessory Trays

91T-0XXX-04
S/N ATZ100000 and up

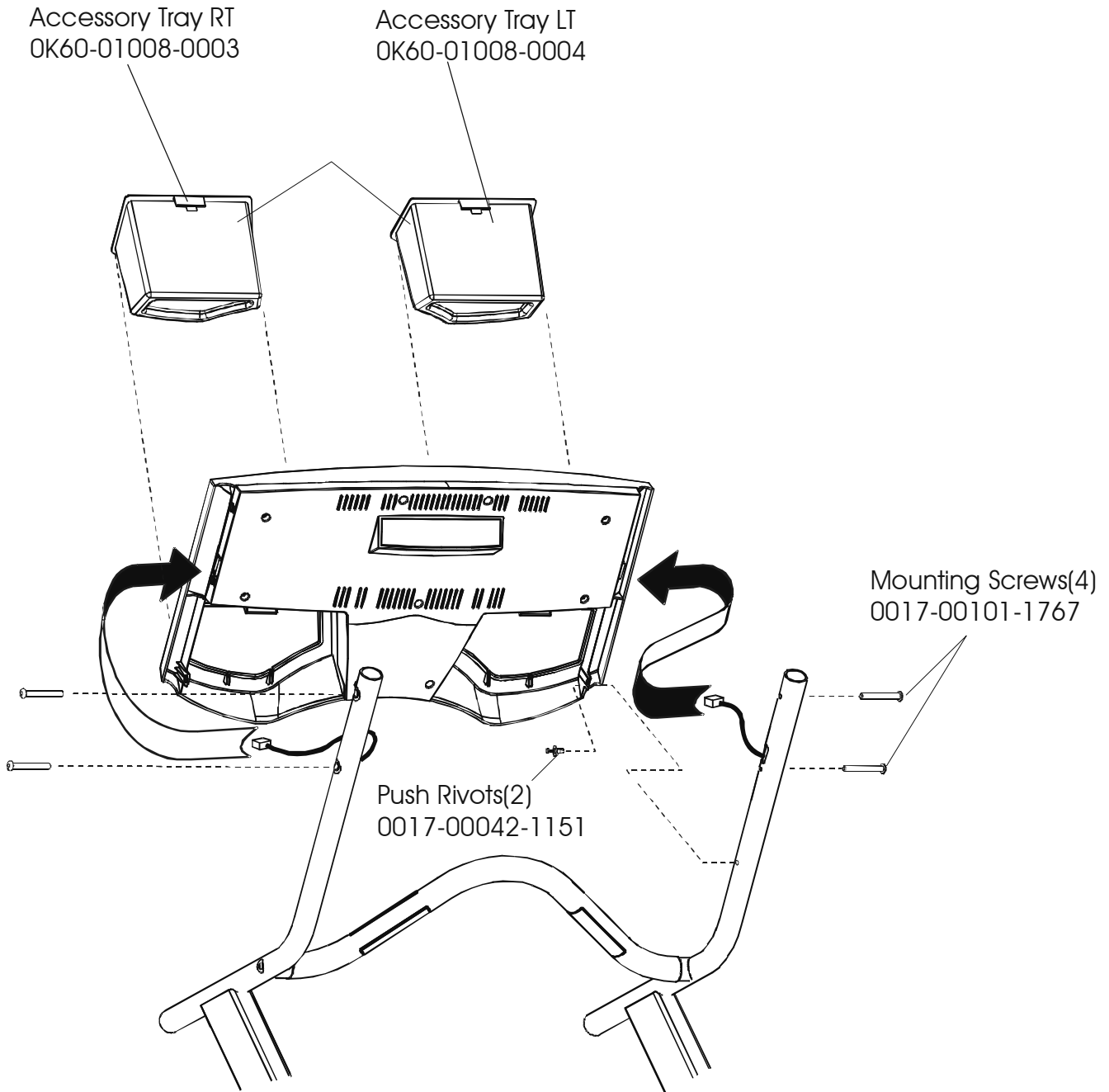

ARCTIC SILVER 91TW

Belt, Deck and Rollers

91T-0XXX-04

S/N ATZ100000 and up

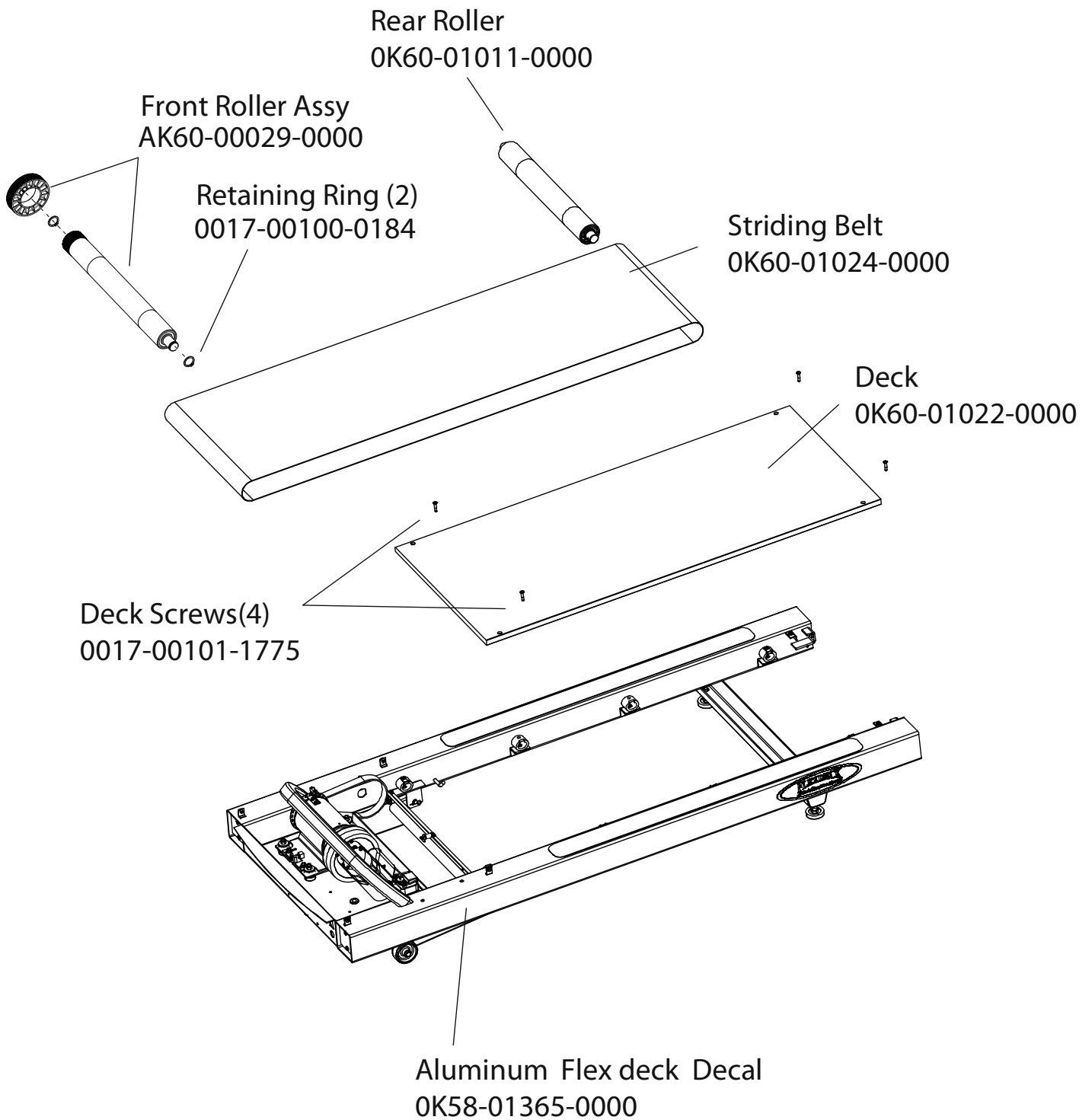

ARCTIC SILVER 91TW
Lifesprings and Anti-Static Tinsel

91T-0XXX-04
S/N ATZ100000 and up

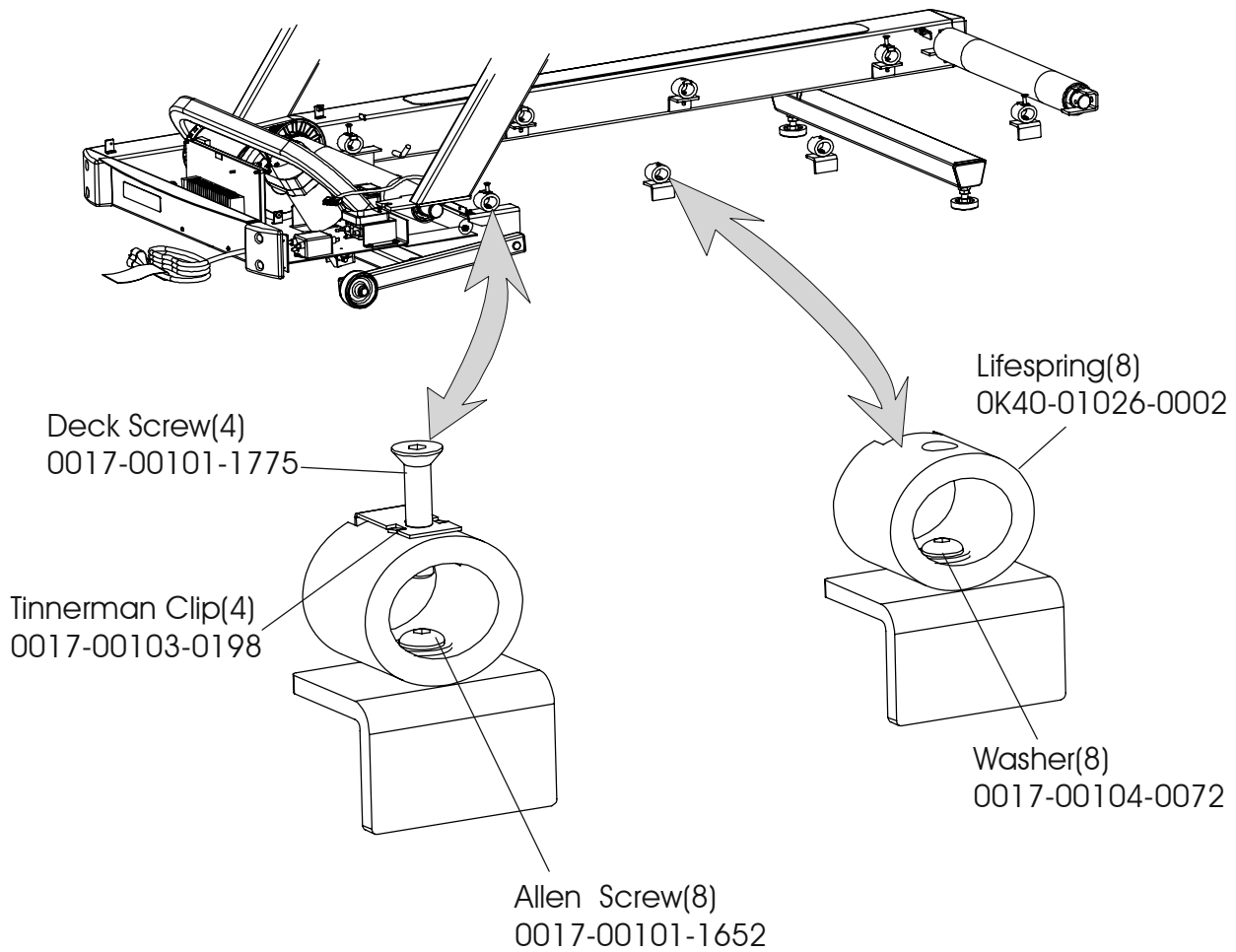
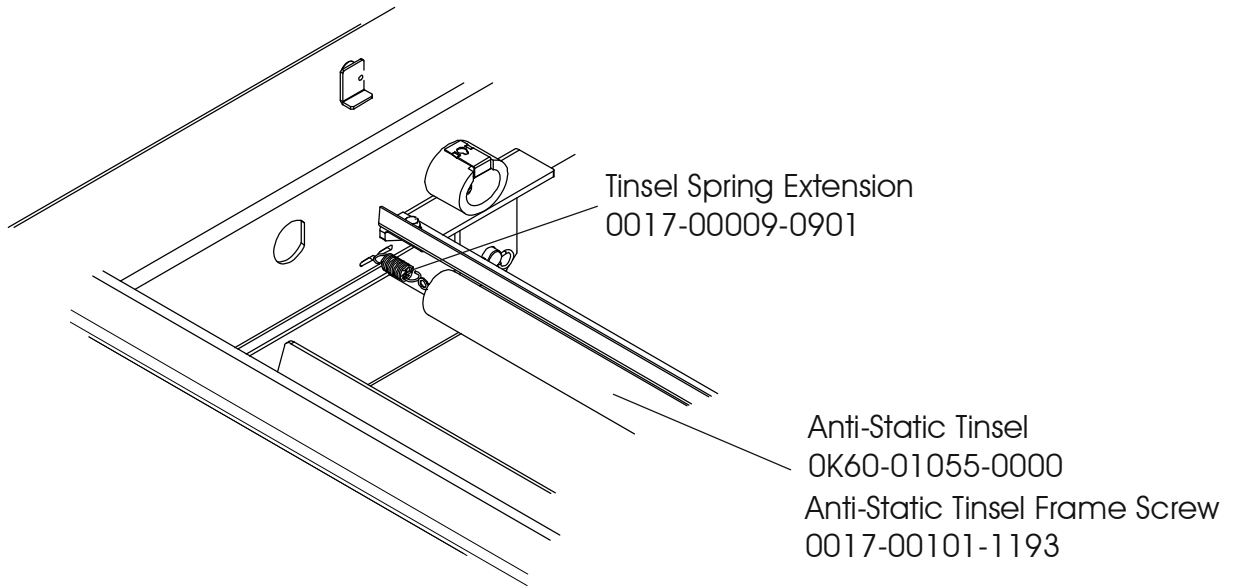

ARCTIC SILVER 91TW

Lift Frame Assembly

91T-0XXX-04

S/N ATZ100000 and up

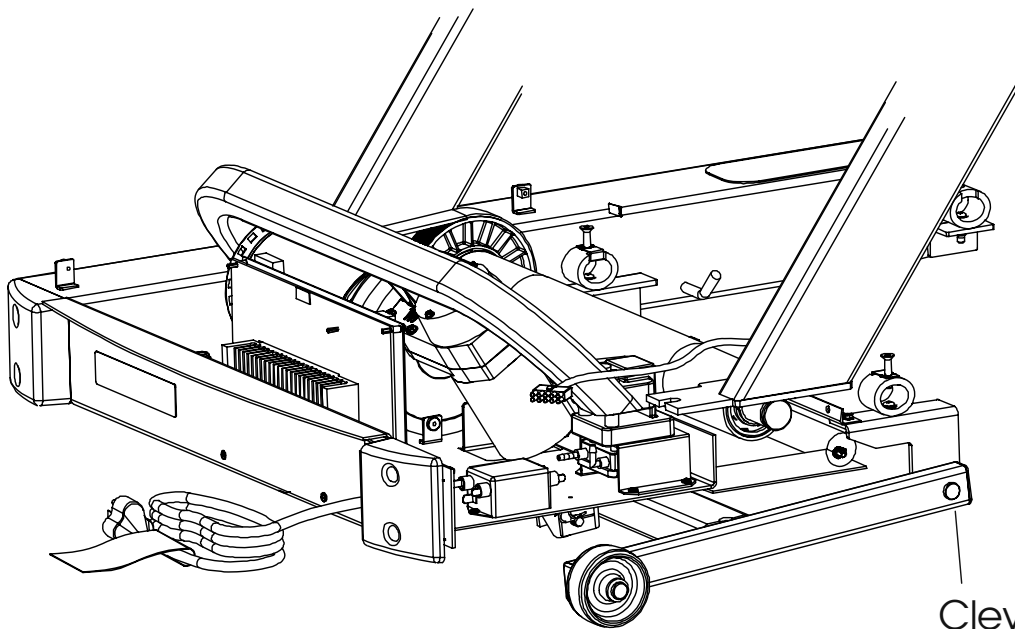

(*)
Included in Lift
Frame Assembly
AK60-00065-0000

- * Lift Arm Wheel
OK60-01020-0000
- * Cap, Tube End
OK60-01092-0000
- * Cotter Pin
0017-00007-0208
- * Clevis Pin
0017-00007-0271

Clevis Pin
0017-00007-0270
Cotter Pin
0017-00007-0208

ARCTIC SILVER 91TW
Lift Motor and Home Switch

91T-0XXX-04
S/N ATZ100000 and up

Lift Motor
OK60-01094-0000 (120v)
OK60-01166-0000(220v/60Hz)

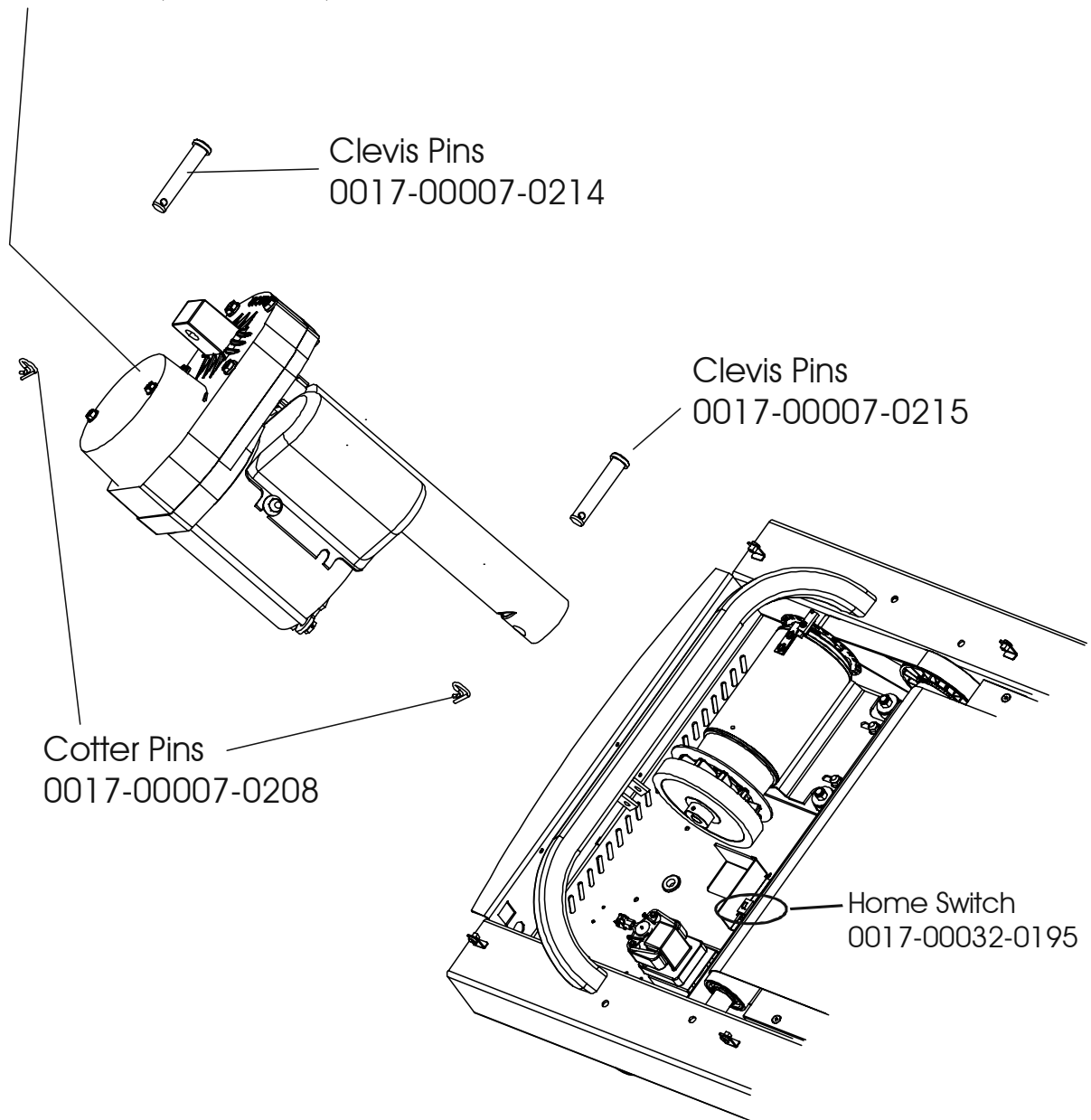

Clevis Pins
0017-00007-0214

Clevis Pins
0017-00007-0215

Cotter Pins
0017-00007-0208

Home Switch
0017-00032-0195

ARCTIC SILVER 91TW

Drive Motor Assembly

91T-0XXX-04

S/N ATZ100000 and up

Drive Motor Assembly
AK60-00081-0001
Motor Brush Kit
GK60-00002-0007

Tensioning Bolt
0017-00101-1283

Mounting Nuts(4)
0017-00103-0132

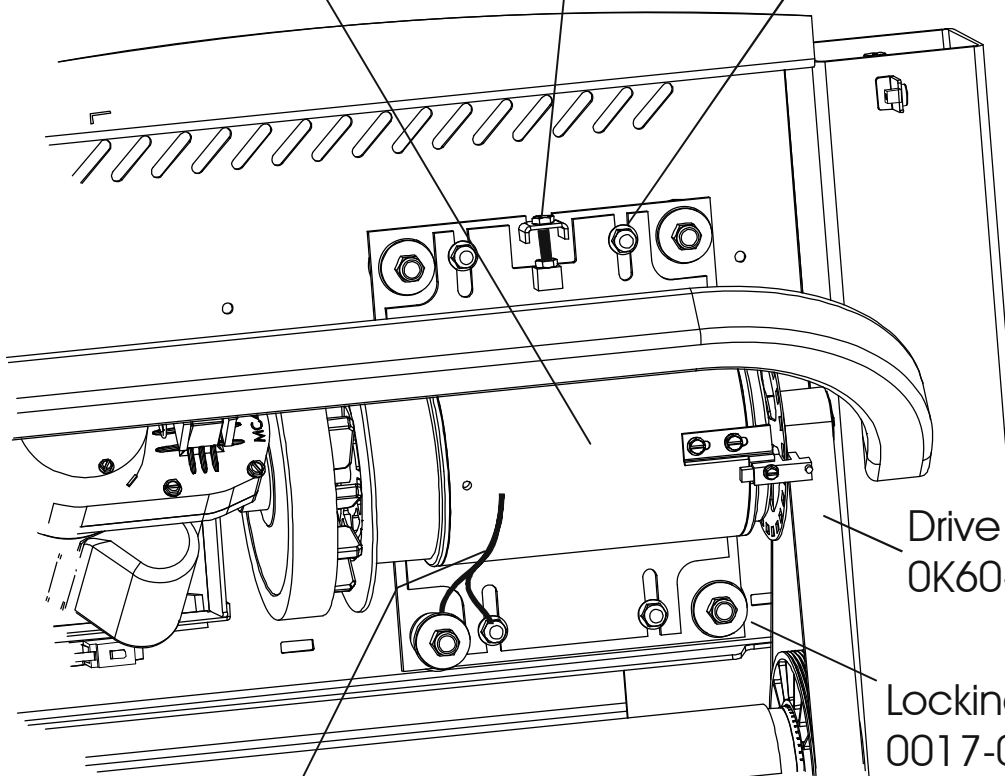

Drive Belt
OK60-01025-0000

Locking Nut
0017-00103-0025

Washer
OK60-01121-0000

Isolation Mount
OK60-01119-0000

Isolation Mounting Plate
OK60-01123-0000

Motor Mount Spacer
OK60-01120-0000

Motor; Bleed Cable
AK60-00098-0000

ARCTIC SILVER 91TW
Wax Pump, Bag, Nozzle and Bracket

91T-0XXX-04
S/N ATZ100000 and up

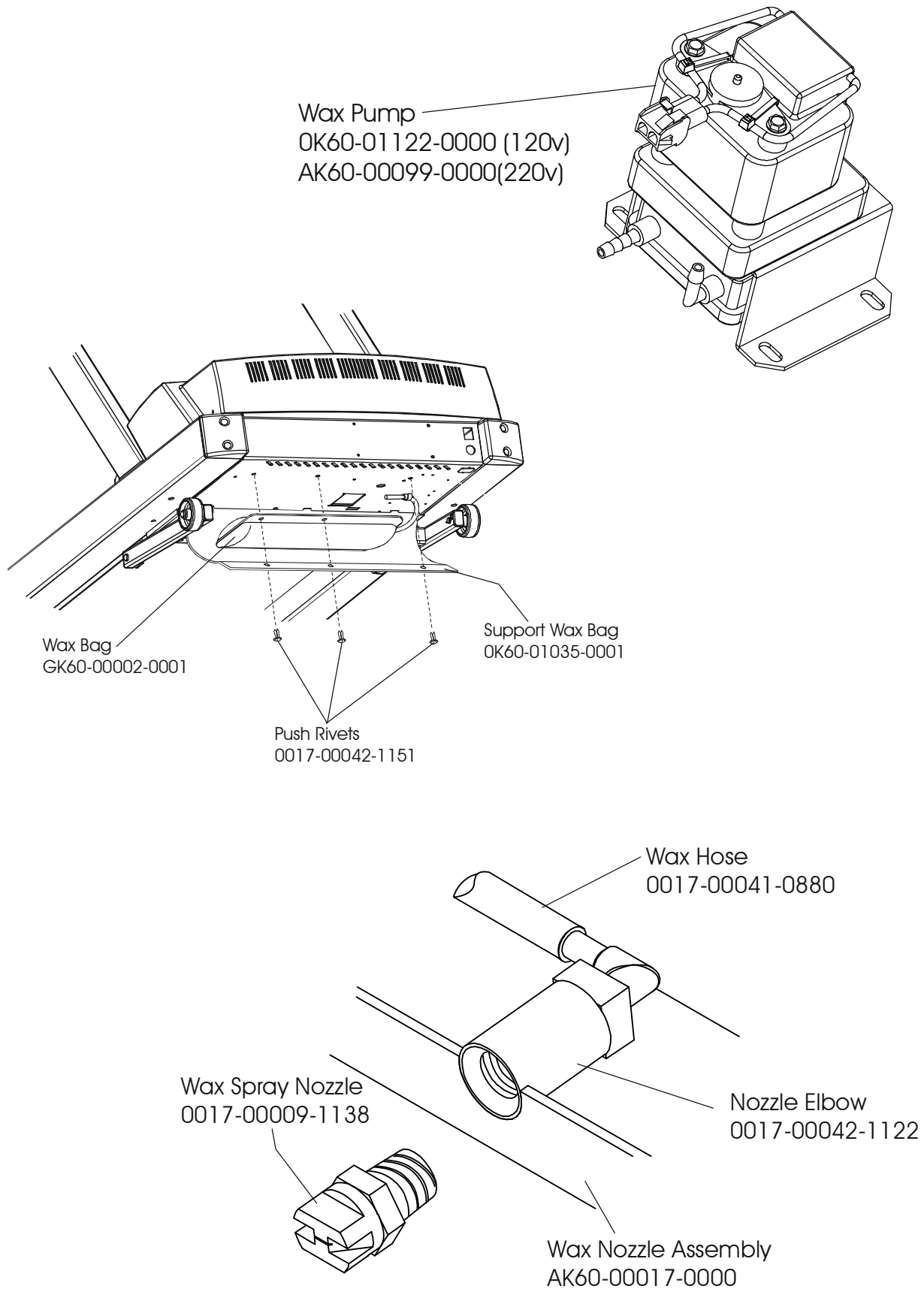

ARCTIC SILVER 91TW

Sensors

91T-0XXX-04

S/N ATZ100000 and up

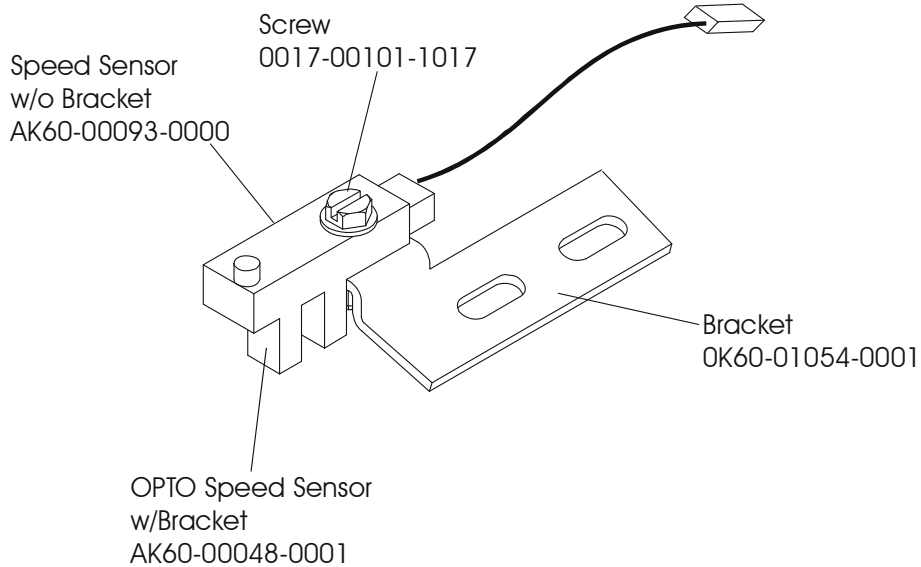
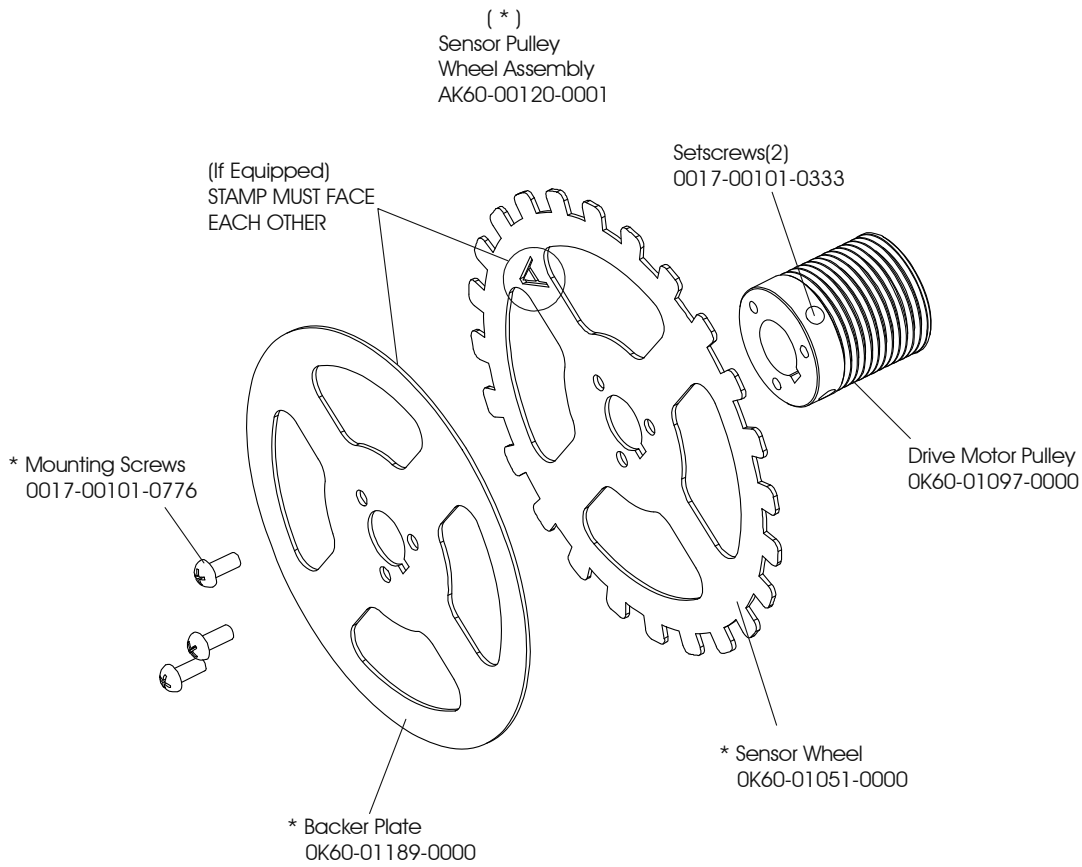

Rear Roller
Cover Guards LT
OK60-01085-0002

Rear Roller
Cover Guards RT
OK60-01085-0001

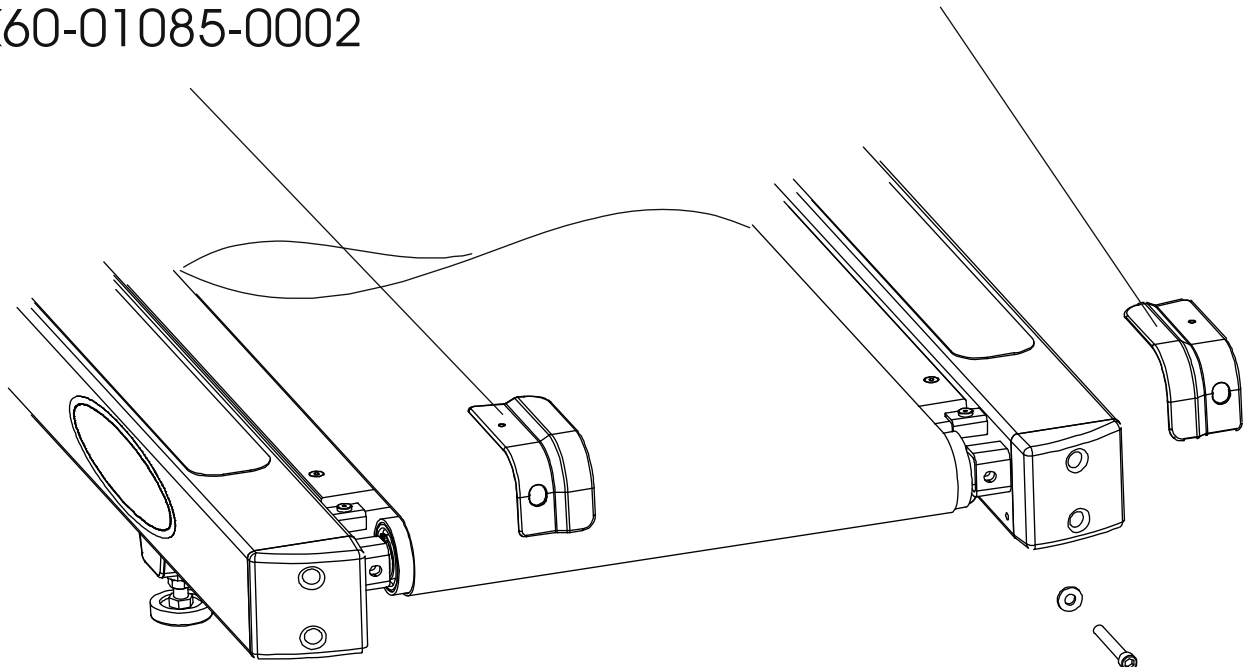

Washer(2)
0017-00104-0334

Rear Roller
Adjusting Bolt(2)
0017-00101-1880

ARCTIC SILVER 91TW
DC Controller and On/Off Switch

91T-0XXX-04
S/N ATZ100000 and up

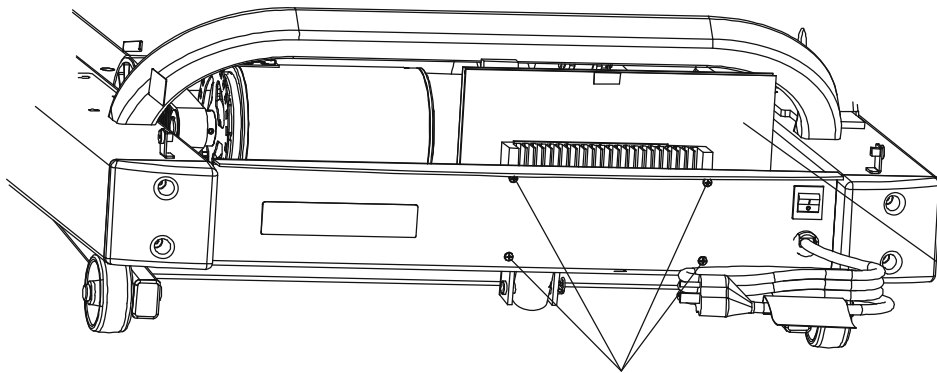

DC Controller
Mounting Screws(4)
0017-00101-0162

DC Controller
GK60-00002-0002
100-120 Volts/50-60 Hz
GK60-00002-0003
200+ Volts/50-60 Hz

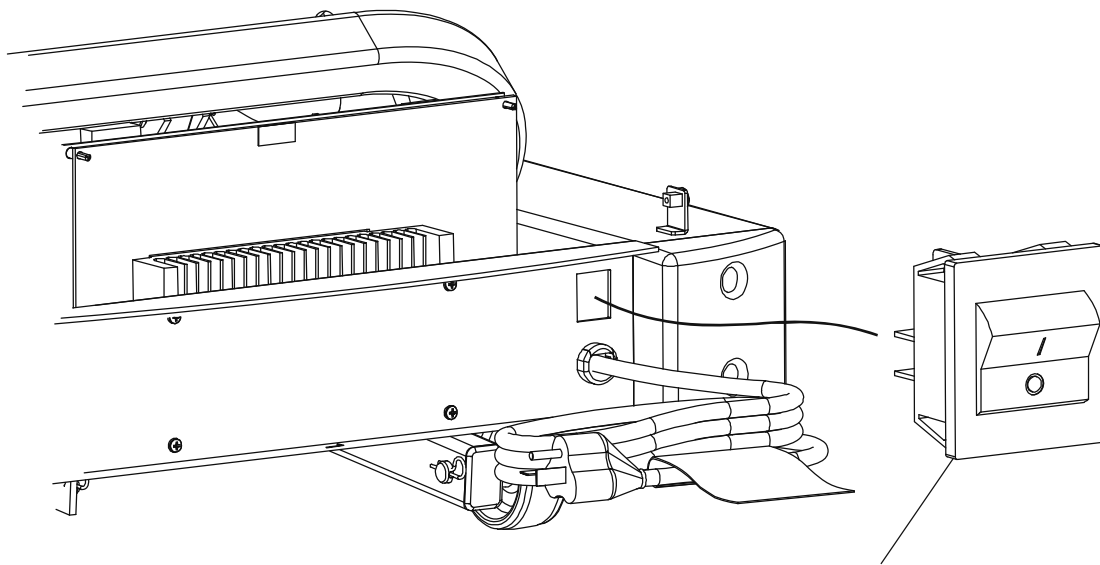

ON/OFF Switch
0017-00032-0198

ARCTIC SILVER 91TW

Line Filter

91T-0XXX-04

S/N ATZ100000 and up

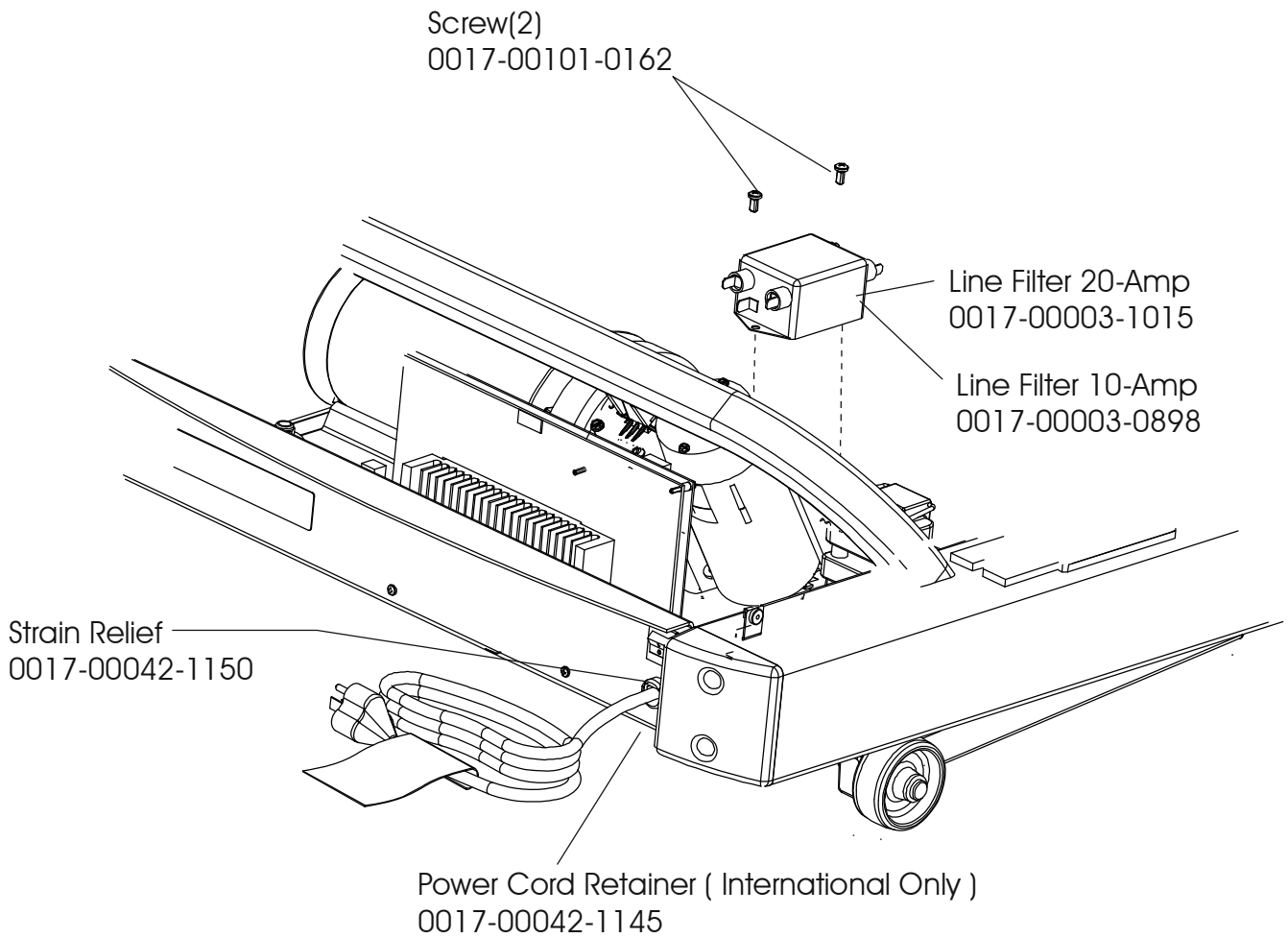

ARCTIC SILVER 91TW
Line-Cords & Line-Cord Options

91T-0XXX-04
S/N TWD100000 and up

MODEL #	MODEL DESCRIPTION	STANDARD LINE-CORDS
91TW-0100-03	91TW ENG/ENG 120/60 DOM	AK60-00067-0000 LINE-CORD ASSY: DOM; NEMA 5-20; 12AWG PURCH. C
91TW-0300-03	91TW FRN/MET 120/60 DOM	
91TW-0400-03	91TW SPN/MET 120/60 DOM	
91TW-0705-03	91TW JAP/MET 100/50 DOM	
91TW-0800-03	91TW POR/MET 120/60 DOM	
91TW-0103-03	91TW ENG+MET 220/60 DOM	0017-00003-0951 LINE-CORD: 220V;DOM;15A 8-FT B
91TW-0706-03	91TW JAP/MET 200/50 DOM	
91TW-0101-03	91TW ENG+MET 230/50 CON	0017-00003-0696 LINE-CORD: R/A; CEE7; 103" 10A 250V D
91TW-0201-03	91TW GER/MET 230/50 CON	
91TW-0301-03	91TW FRN/MET 230/50 CON	
91TW-0401-03	91TW SPN/MET 230/50 CON	
91TW-0501-03	91TW ITL/MET 230/50 CON	
91TW-0601-03	91TW DUT/MET 230/50 CON	
91TW-0801-03	91TW POR/MET 230/50 CON	
91TW-0102-03	91TW ENG+MET 240/50 UK	0017-00003-0890 LINE-CORD: U.K; R/A D
91TW-0109-03	91TW ENG+MET 230/50 UK	
91TW-0104-03	91TW ENG+MET 240V+ AUS	0017-00003-0996 LINE-CORD: IEC; AUSTRALIAN; 230/50 C

OPTIONAL LINE-CORDS		
0017-00003-0952	LINE-CORD: 20A; 120V; 12'	12'
0017-00003-0981	LINE-CORD: R/A; W/PLUG 220/60	7.5'
0017-00003-0948	LINE-CORD: 220V; 15A;	12'

ARCTIC SILVER 91TW

Cables

91T-0XXX-04

S/N ATZ100000 and up

